



Cisco Expo  
2008

# Aplikace nad metropolitní WiFi infrastrukturou (TECH3)



**Pavel Křížanovský**

Systems Engineer, CCIE#11457

[pkrizano@cisco.com](mailto:pkrizano@cisco.com)

**Enable Your Network  
Empower Your Business**

# Agenda

- Úvod do metropolitní a outdoor WiFi
- Technologie a architektury pro metropolitní sítě WiFi
  - Komponenty WiFi Mesh
  - Vlastnosti WiFi Mesh
  - End-to-end architektura metropolitních WiFi sítí
  - Zajímavé produkty
- Aplikace
  - Využití jedné fyzické infrastruktury pro oddělené logické sítě
  - Fyzická bezpečnost, kamerové systémy
  - Mobilita, dopravní prostředky
  - Služby lokalizace, informace pro turisty
  - Digital Media Signage



# Agenda

- Úvod do metropolitní a outdoor WiFi
- Technologie a architektury pro metropolitní sítě WiFi
  - Komponenty WiFi Mesh
  - Vlastnosti WiFi Mesh
  - End-to-end architektura metropolitních WiFi sítí
  - Zajímavé produkty
- Aplikace
  - Využití jedné fyzické infrastruktury pro oddělené logické sítě
  - Fyzická bezpečnost, kamerové systémy
  - Mobilita, dopravní prostředky
  - Služby lokalizace, informace pro turisty
  - Digital Media Signage



# Outdoor wireless – what do we need to solve ?

- Outdoor wireless access to wired networks
  - => Outdoor APs
- Networks interconnection via wireless
  - => Outdoor Wireless Bridging
- Outdoor areas wireless coverage

=> **Wireless Mesh**

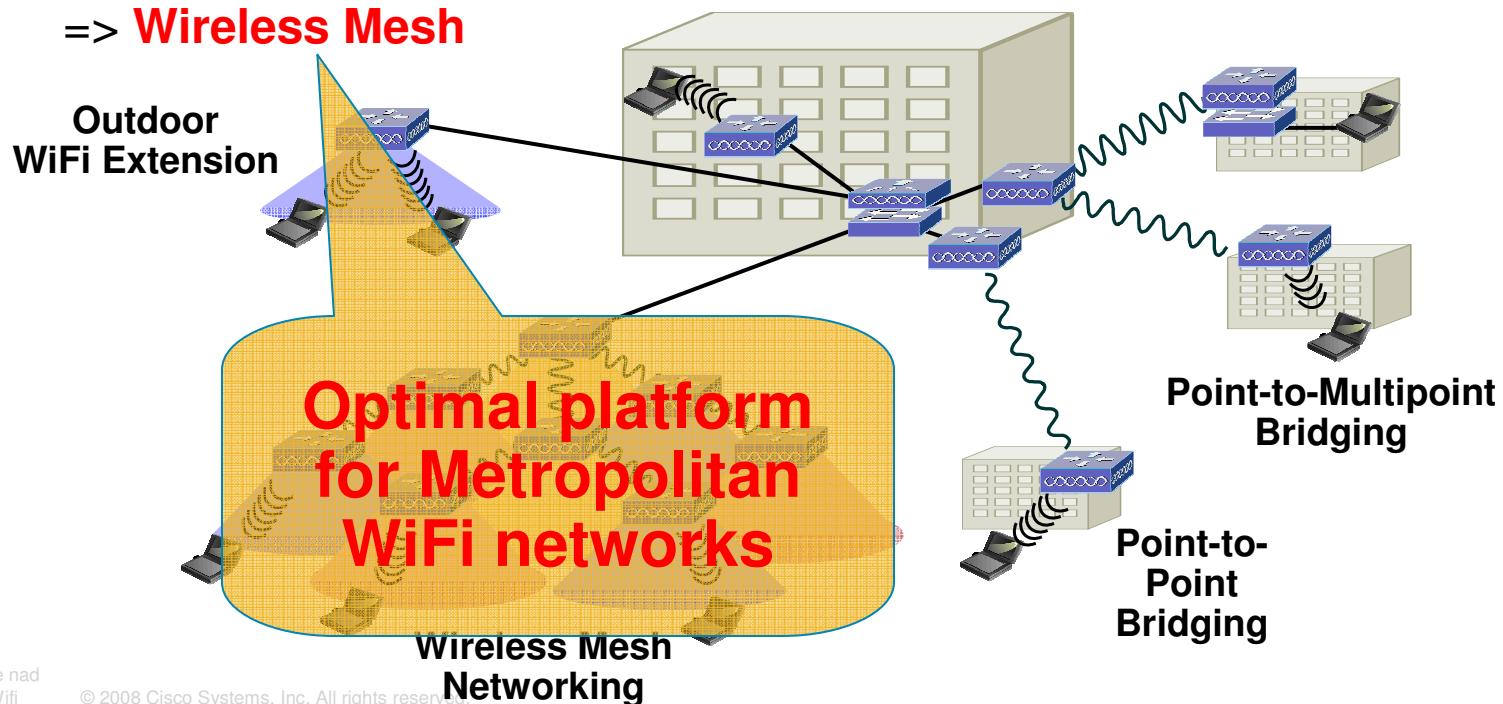

# What is wireless mesh ?

**APs are interconnected via wireless**  
**Wireless backhaul topology is**  
**automatically created**

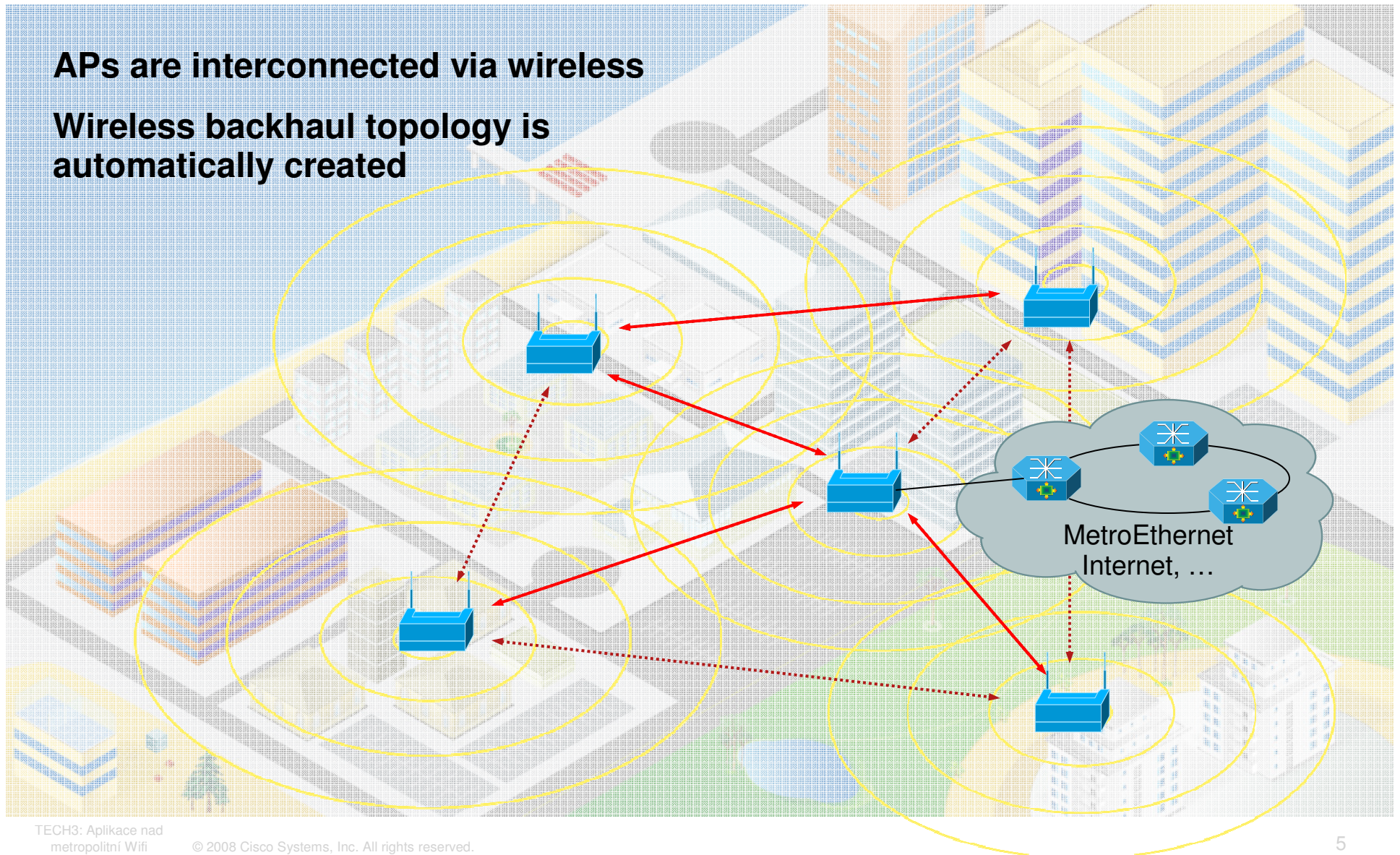

# Agenda

- Úvod do metropolitní a outdoor WiFi
- **Technologie a architektury pro metropolitní sítě WiFi**
  - Komponenty WiFi Mesh
  - Vlastnosti WiFi Mesh
  - End-to-end architektura metropolitních WiFi sítí
  - Zajímavé produkty
- Aplikace
  - Využití jedné fyzické infrastruktury pro oddělené logické sítě
  - Fyzická bezpečnost, kamerové systémy
  - Mobilita, dopravní prostředky
  - Služby lokalizace, informace pro turisty
  - Digital Media Signage



# Outdoor Wireless Mesh Solution Components

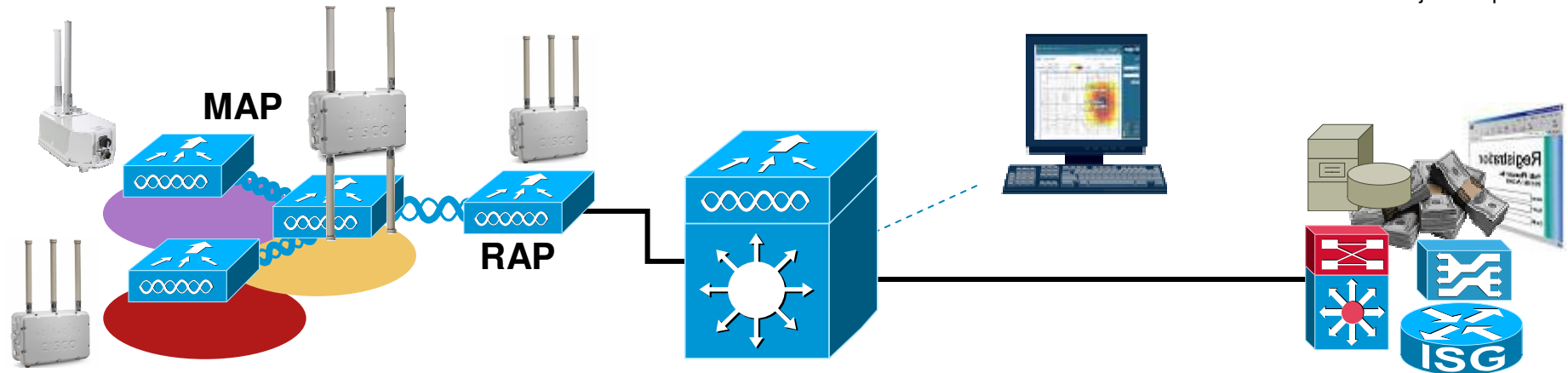

Mesh Access Point	Root Access Point	Wireless LAN Controller	Wireless Control System (WCS)	Back Office Systems
<ul style="list-style-type: none"> <li>• 802.11b/g client access</li> <li>• Connects to Root AP via 802.11a</li> <li>• AC/DC power; PoE capable</li> <li>• Ethernet port for connecting peripheral devices (POE)</li> <li>• Battery backup</li> </ul>	<ul style="list-style-type: none"> <li>• Serves as “Root” AP to the wired network</li> <li>• Typically located on roof-tops or towers</li> <li>• Connects up to 35 Mesh APs using 802.11a</li> <li>• Access QoS and encryption</li> </ul>	<ul style="list-style-type: none"> <li>• Links Wireless Mesh APs to wired network</li> <li>• Handles RF algorithms and optimization</li> <li>• Seamless WiFi mobility</li> <li>• Provides security/mobility mgt</li> </ul>	<ul style="list-style-type: none"> <li>• Wireless Mesh Management System enables network-wide policy configuration and device management\</li> <li>• SNMPv3, Syslog, IPsec, AAA, etc</li> </ul>	<ul style="list-style-type: none"> <li>• Bandwidth Monitoring and Management</li> <li>• Policy Definitions</li> <li>• Subscriber Database Management</li> <li>• Billing and OSS Systems</li> </ul>

**Industry Proven Devices at Every Layer**

**Reliable Hardware**

# Cisco Intelligent Wireless Mesh Solution

- Ease of Deployment & Management
  - Identical Indoor/Outdoor Management
  - Based on LWAPP
    - Used for automatic AP management , and data tunneling
  - Self-Configuring,  
(Zero-Touch Configuration)
  - Self-Healing Mesh  
(Cisco's new Adaptive Wireless Path –AWP- Protocol)
- 802.11e QoS Capable
- Robust Embedded Security
- Seamless L3 Mobility

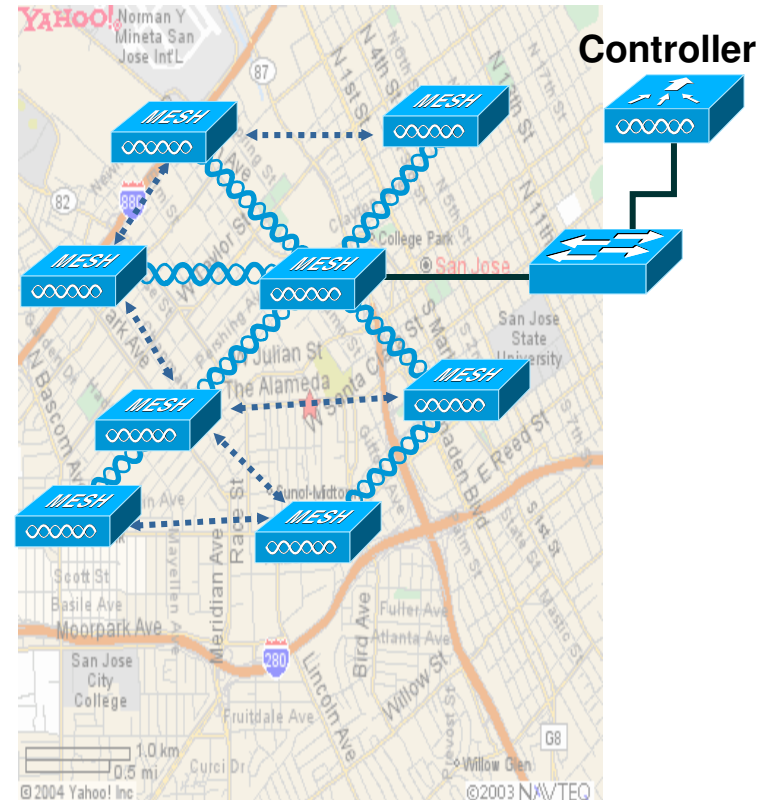



# Providing Security at Each Step

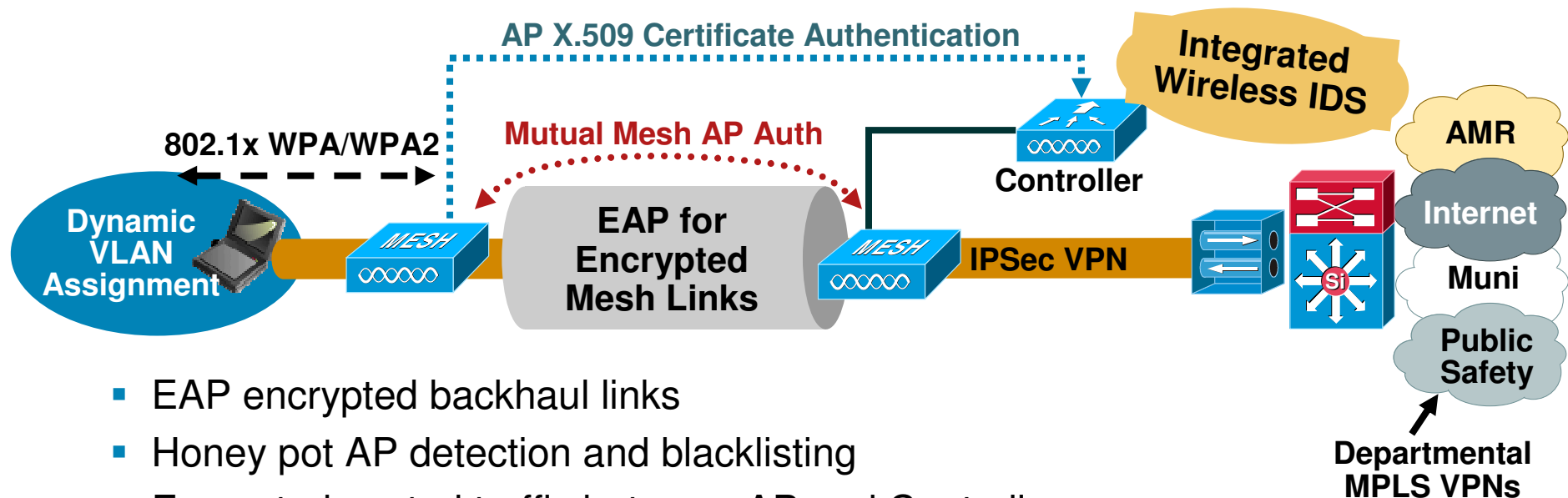

- EAP encrypted backhaul links
- Honey pot AP detection and blacklisting
- Encrypted control traffic between AP and Controller
- Integrated Wireless IDS and Attack correlation software
- Dynamic WLAN VLAN assignment + 802.11i WPA/WPA2 security
- Mobile IPsec VPNs for “confidential” mesh client traffic

Cisco’s new Mobile VPN Client uninterrupted IPsec roaming between Wi-Fi, cellular, etc. networks

Secure  
Control

Delivering Mission-Critical Wi-Fi Access

# Distances and coverage

- Typical distances

  - RAP to MAP : 200-800 m

    - Location are towers or tall buildings

  - MAP to MAP : 100-200 m

    - Locations are short buildings top or street lights

    - More subject to interference, noise, non-LOS, multi-path

  - MAP to Client : 80-150 m

  - MAP should not exceed

    - 12m height above street

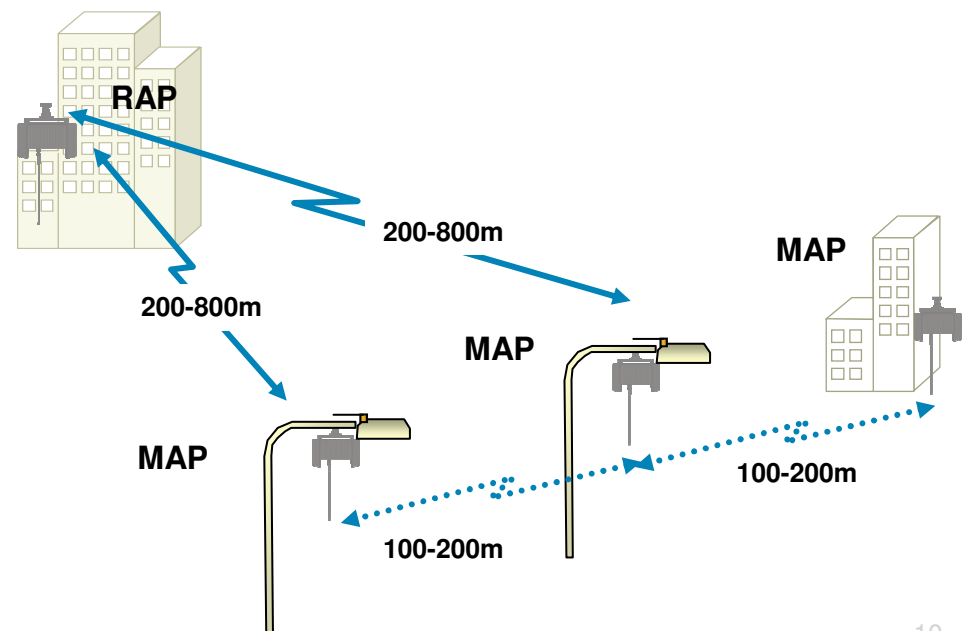

# Distances and coverage

- Typical minimal coverage is 12/13 cells for  $\sim 1\text{km}^2$   
Greenfield installations  
More for historical citycenters
- Design impact of RF Shadow and beyond coverage

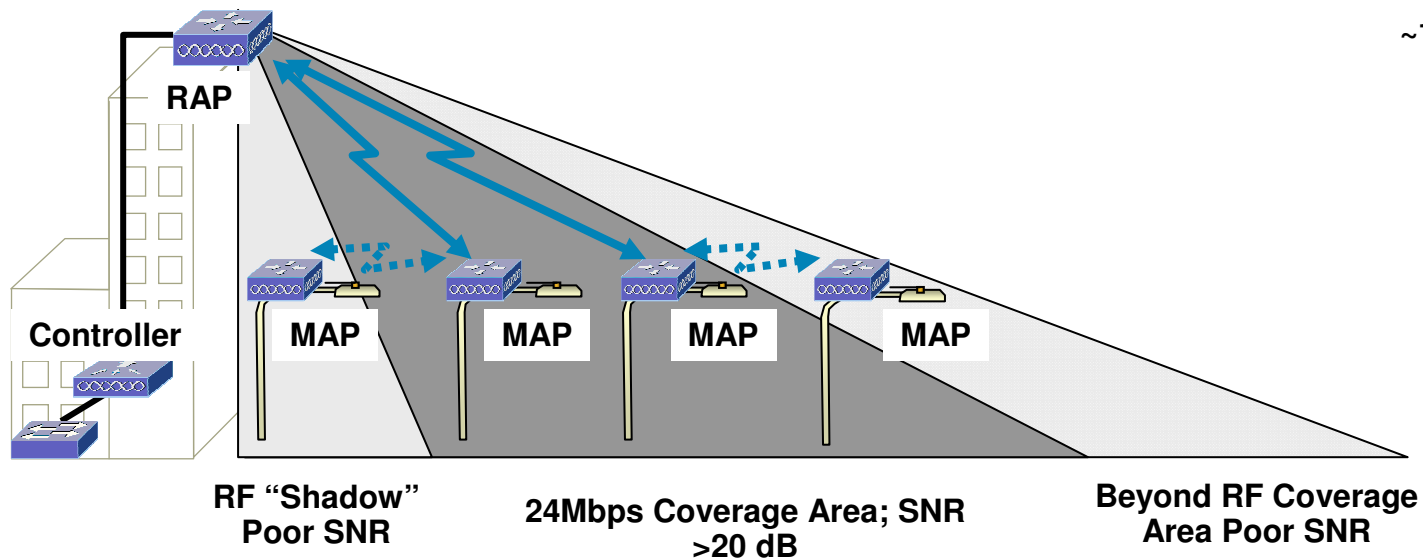
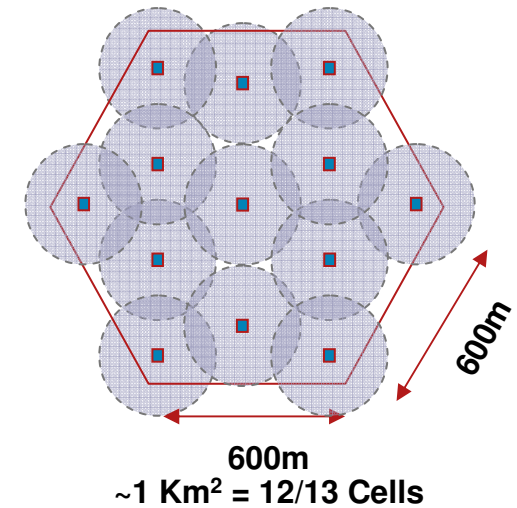

# Bandwidth & number of hops

- 8 hops depth theoretical maximum, max 3-4 hops recommended
- Adding hop level impacts overall throughput
- ~2 / 3 msec latency per hop
- 24 Mbps is the default fixed rate set for the backhaul (recommended)
- Data rates for all the MAPs/RAPs in a bridge group must match

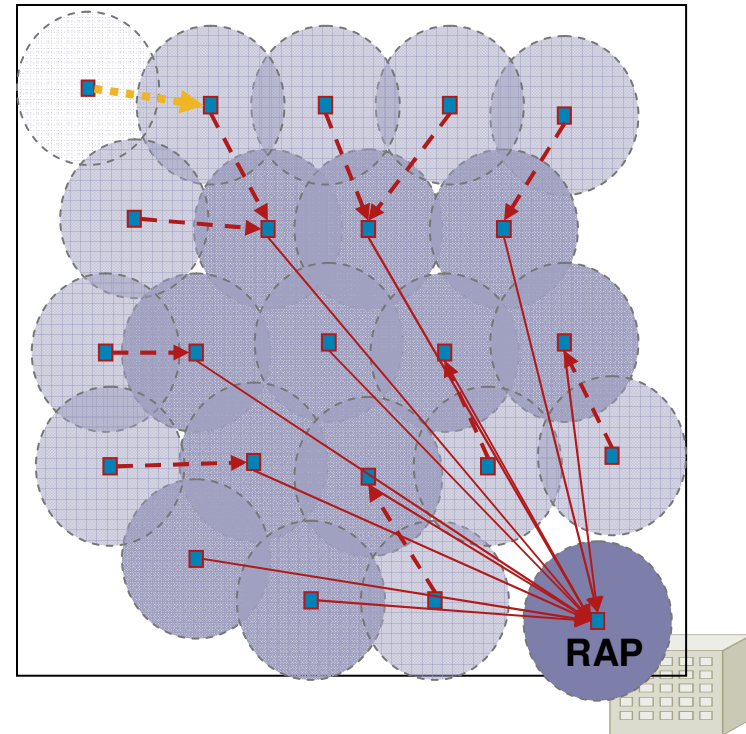

Hops	1	2	3	4
Throughput BH 18 Mbps	~10Mbps	~5Mbps	~3Mbps	up to 1Mbps
Throughput BH 24 Mbps	~14Mbps	~7Mbps	~4Mbps	up to 1Mbps

# Comparison of Same Hop Depth Level Throughput (BH rate set to 18Mbps)

Komponenty WiFi Mesh  
**Vlastnosti WiFi Mesh**  
 End-to-end architektura  
 Zajímavé produkty

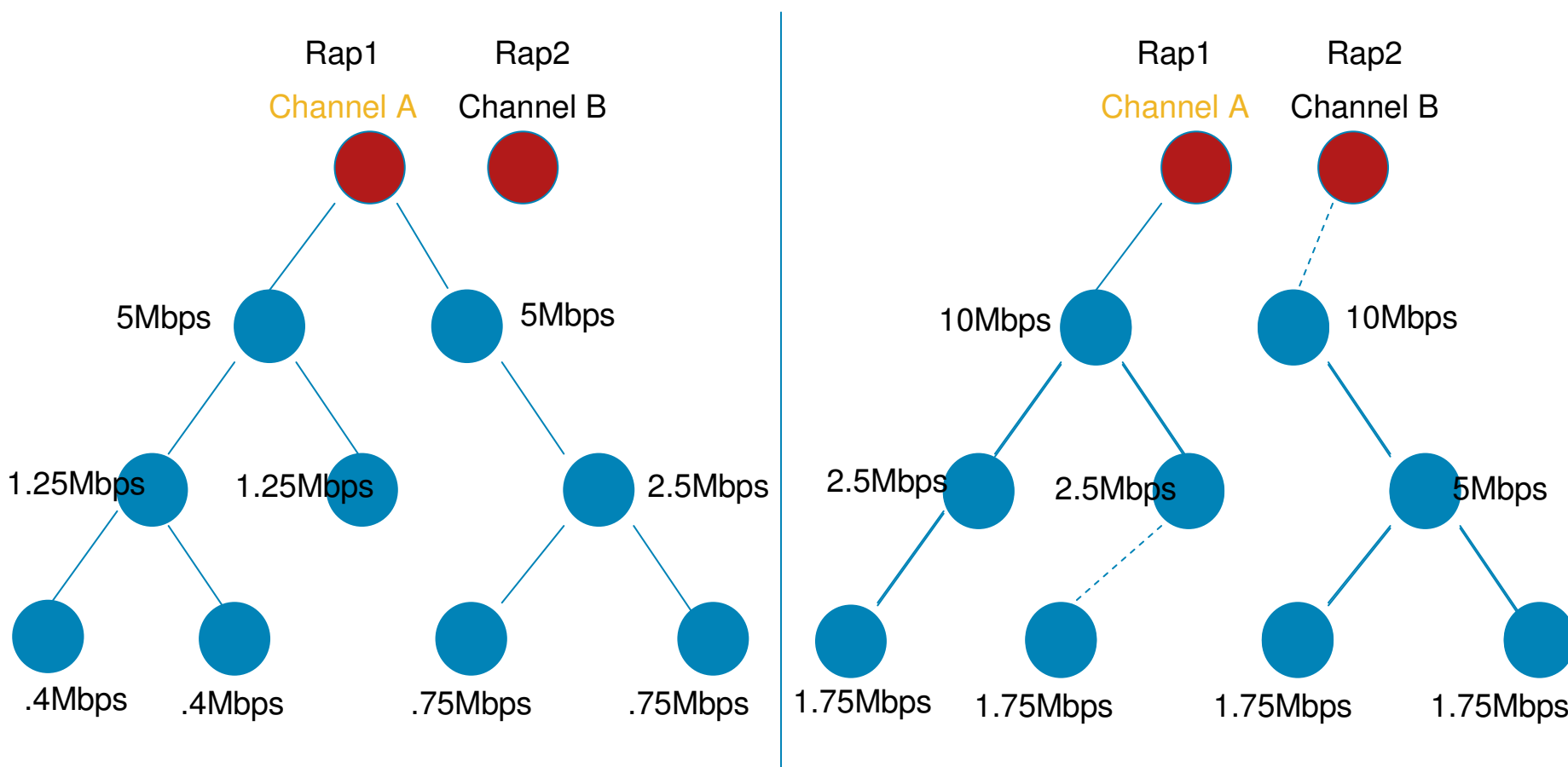

\*Assumes 100% duty cycle. Assuming equal sharing of bandwidth across the same Hop level. Cumulative Bandwidth shown is max across hop level given equal sharing with siblings. When looking at a level, assume that node consumes all bandwidth the parent had available, given the parent stops delivering the computed TPUT to its clients.

# Cisco IP Next-Generation Network (NGN) Architecture

Komponenty WiFi Mesh  
 Vlastnosti WiFi Mesh  
 End-to-end architektura  
 Zajímavé produkty

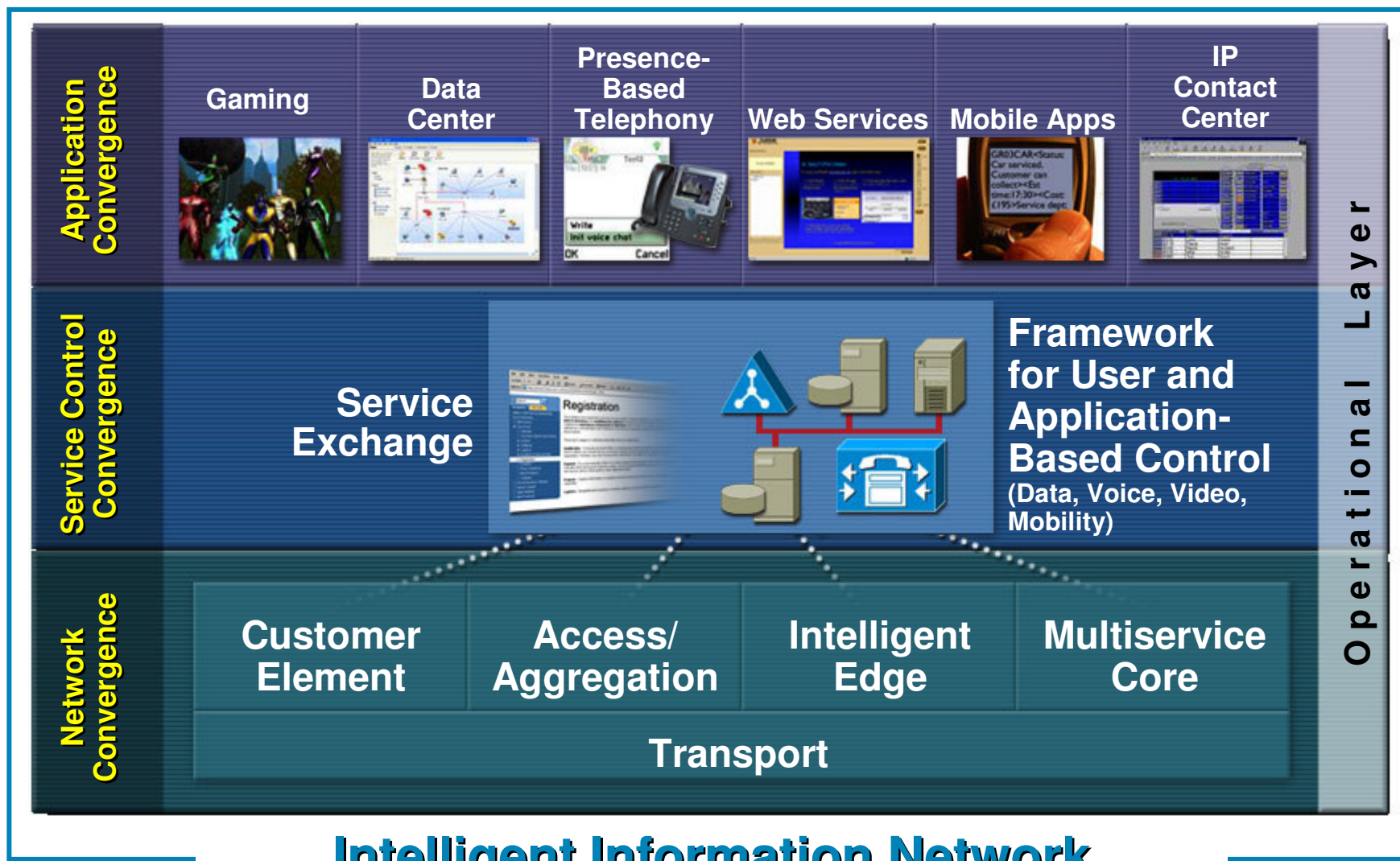

## Intelligent Information Network

# Cisco IP NGN Architecture and ServiceMesh Design

Komponenty WiFi Mesh  
 Vlastnosti WiFi Mesh  
 End-to-end architektura  
 Zajímavé produkty

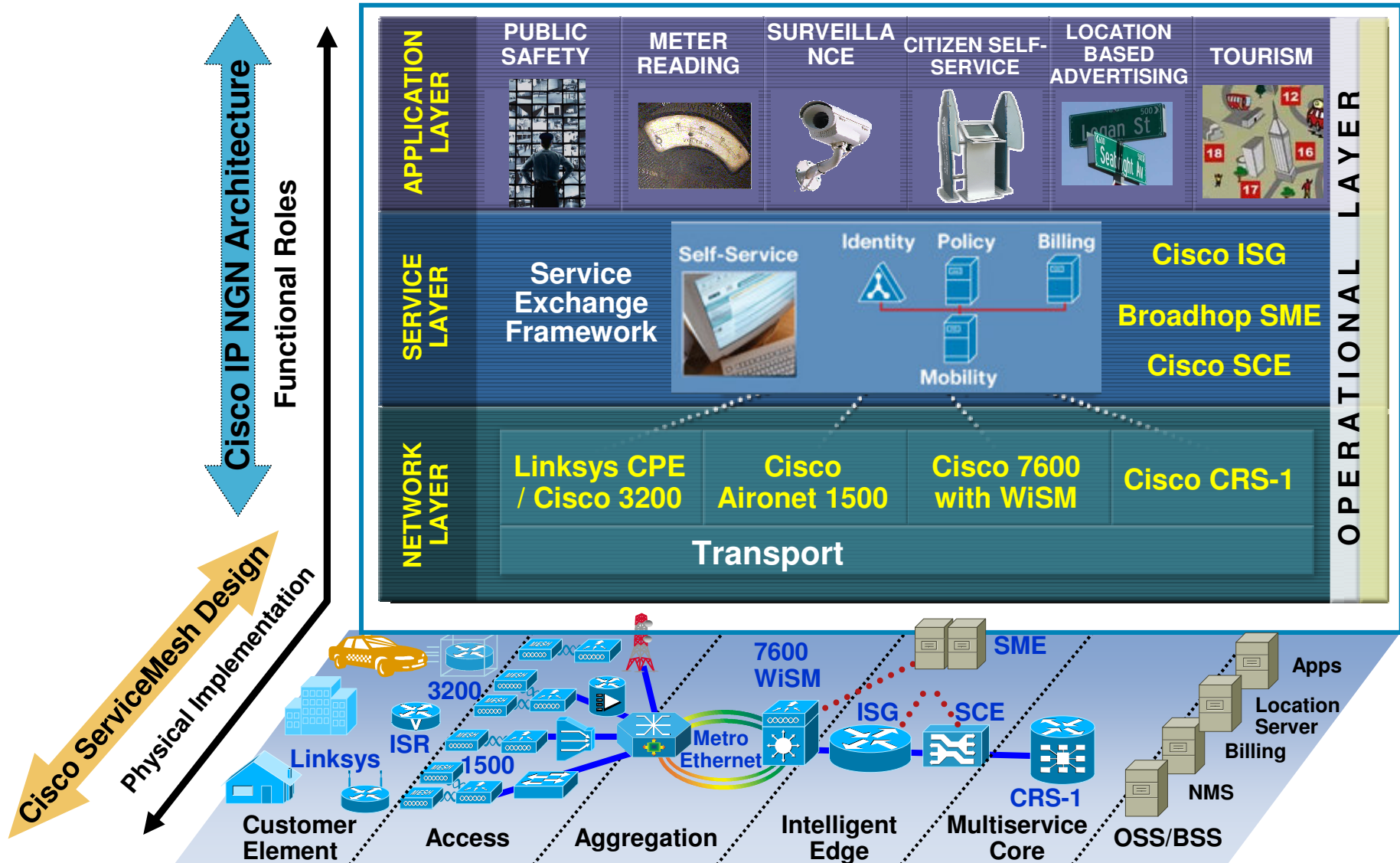

# Service Exchange Layer

- Service control

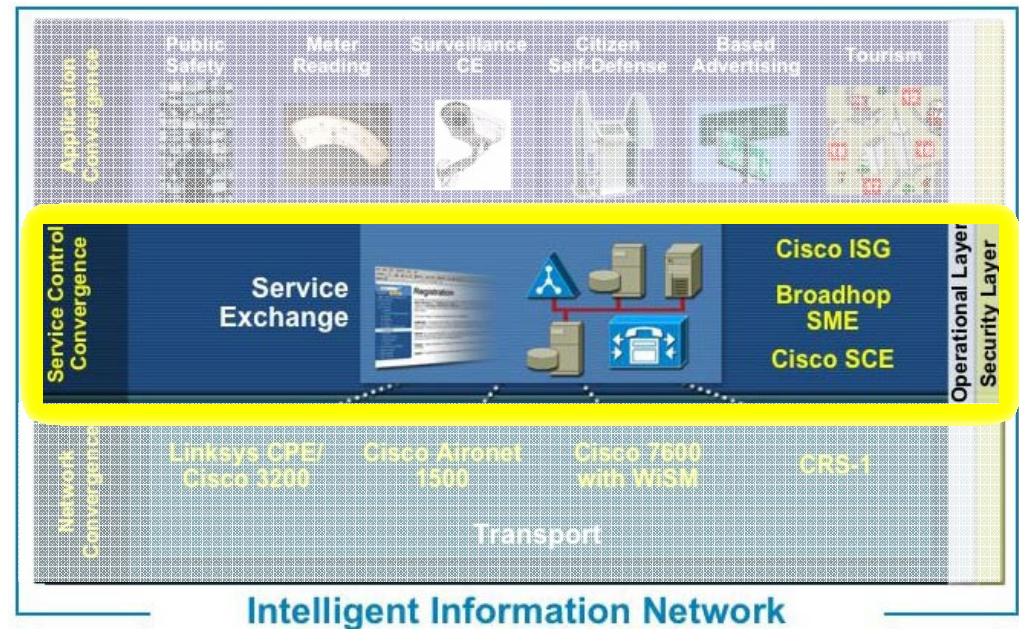
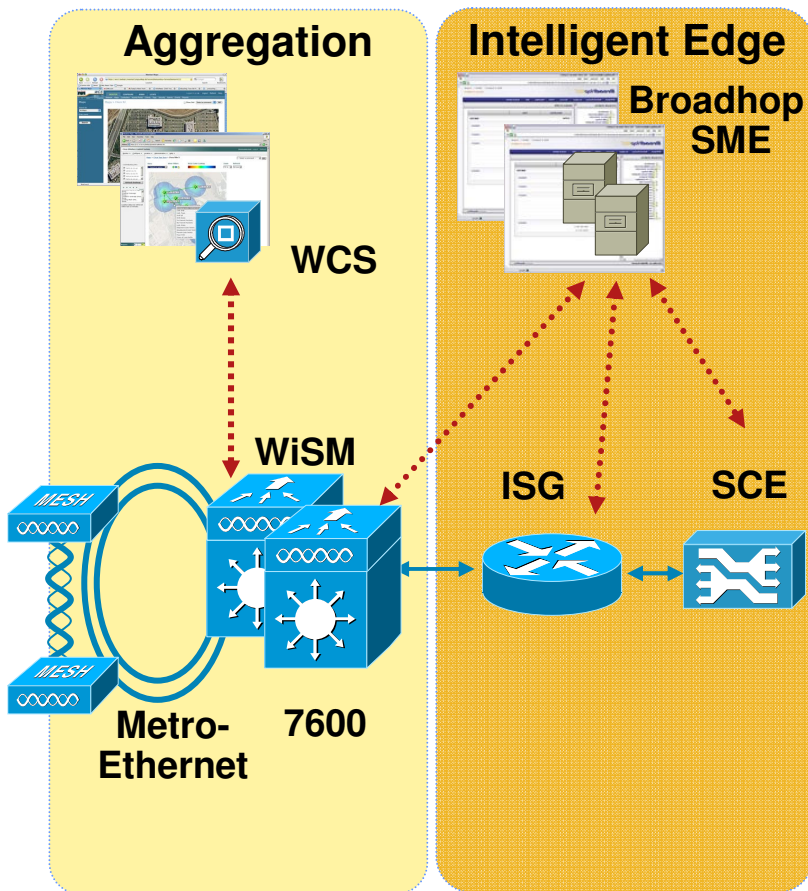



# Product Positioning

Komponenty WiFi Mesh  
 Vlastnosti WiFi Mesh  
 End-to-end architektura  
 Zajímavé produkty

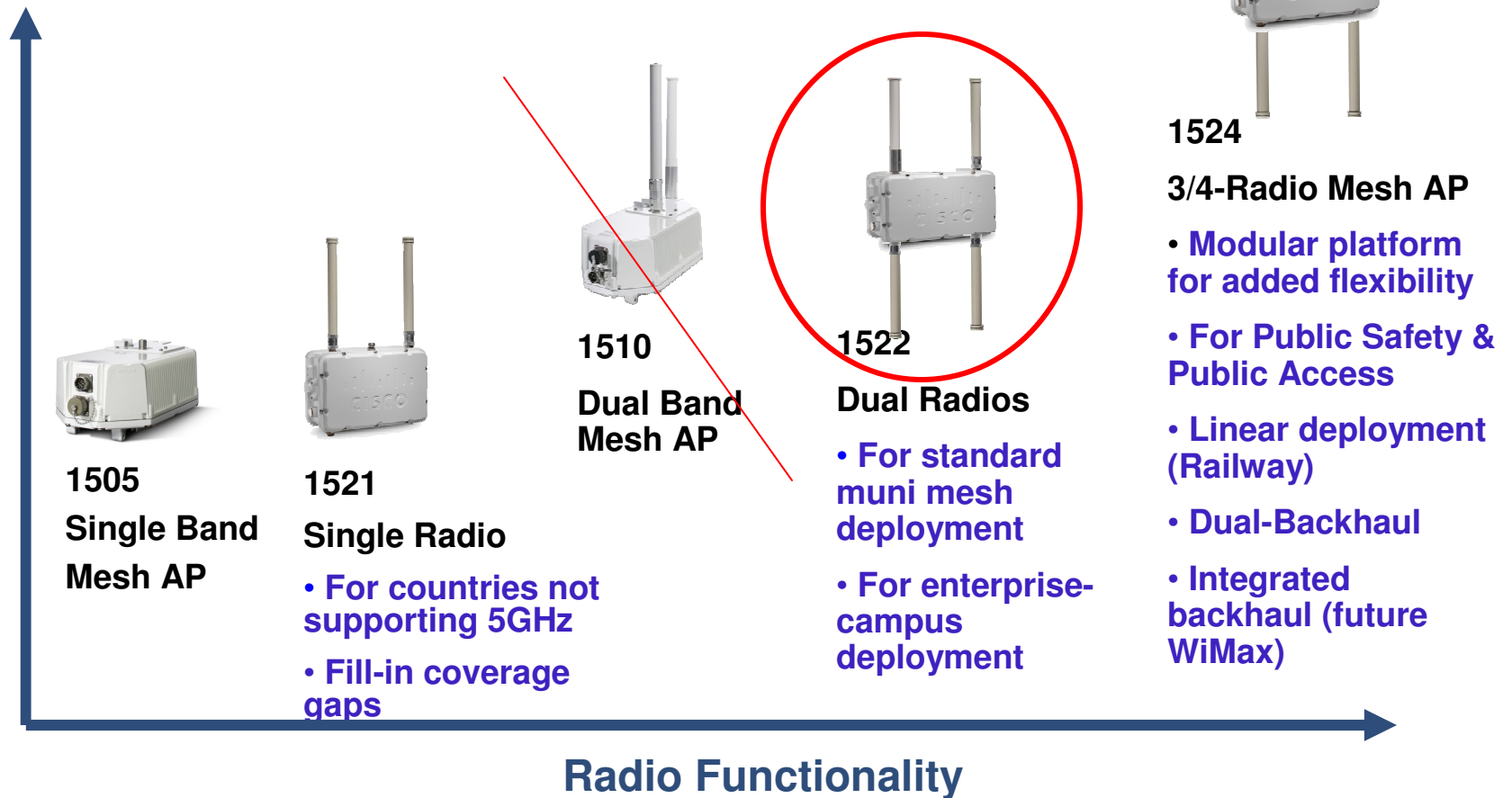

# Cisco 1520 Mesh AP

- Modular design to maximize flexibility, **higher performance**, IOS Platform
- Dual-band 802.11a (4.9 to 5.8 GHz) for Backhaul, 802.11b/g 2.4GHz for Access
- Improved higher power radio performance
  - 5 levels of transmit power (no antenna)
  - 5 GHz: 28 dBm
  - 2.4GHz: 28 dBm / 14dBm ETSI
  - 4.9GHz: 20 dBm (Mask M), 20 MHz channels
- Antennas to maximize EIRP
- Uplink options
  - ~~Cable Modem DOCSIS 2.0 with Cable Power Supply~~
  - Fiber Interface with 100BaseBX SFP
  - 1000BT Gig Ethernet
- Internal Battery Backup
- POE out (802.3af) to power peripheral devices
- Ruggedized **Paintable** Enclosure
  - 40 to +55 C with Solar Loading
  - IP67, NEMA 4X
  - 165 MPH wind gusts, 100 MPH sustained winds
  - Hazardous Loc Class 1, Zone/Div 2**

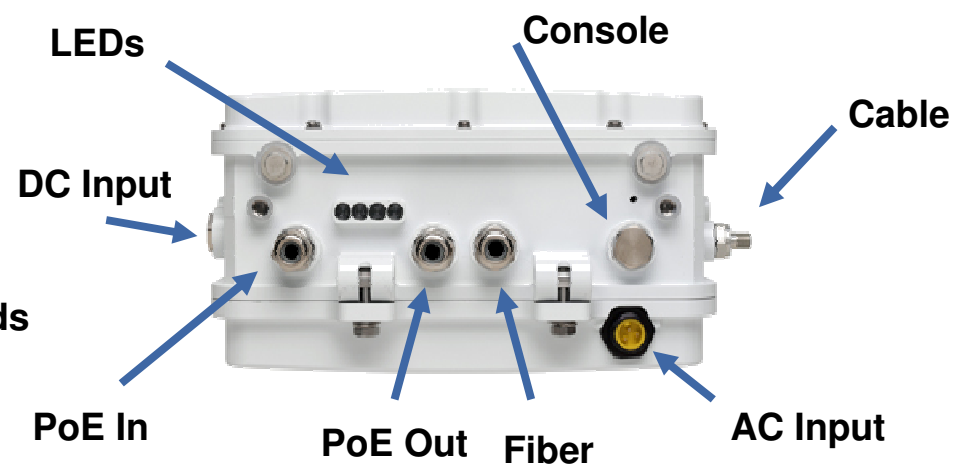

## ➤ Federal Compliance (FIPS 140-2)

# Cisco Wireless Controller Family

4400, WiSM(6500/7600) & 2106 Platforms supported for Mesh

## Network Device Limits

4400 (100 APs)

RAPs	MAPs
1	149
50	100
75	50

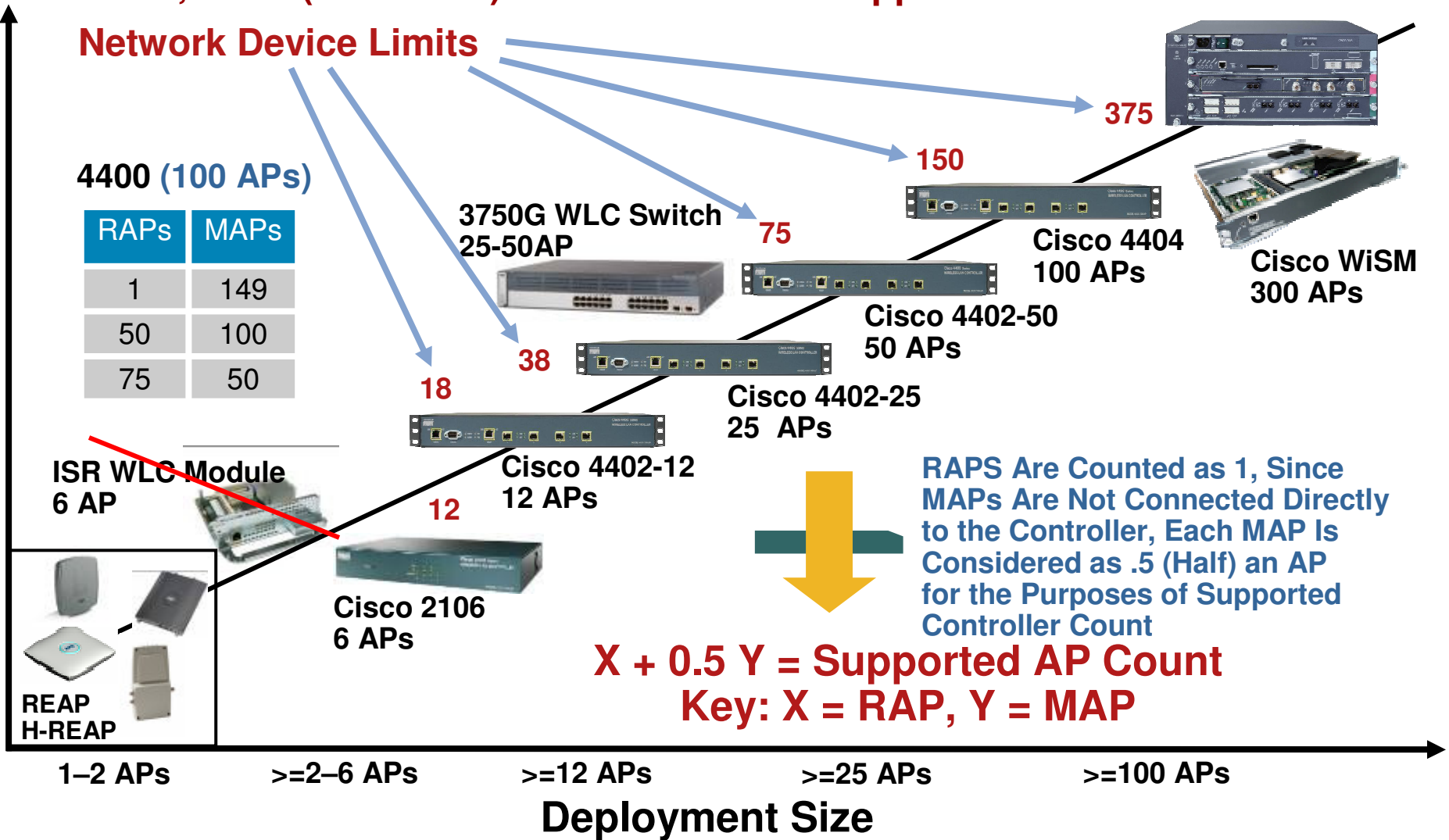

# WCS Mesh Management

The screenshot displays a network map with several Access Points (APs) and their connections. Overlaid windows provide detailed information:

- AP 'huck-map-1' Info:**

AP Info	
MAC Address	00:17:94:fe:a3:b0
AP Model	AIR-LAP1521AG-A-K9
Location	default_location
AP Height	30.0 feet
Mesh Info	
Parent	00:12:94:fe:a3:a0
Num. of children	0
Role	MAP (MeshAP)
Group Name	huck-44...
Backend Interface	802.11a
Data Rate	6 Mbps
Channel	163
- Running Ping Test:**

Controller IP Address	172.19.28.44
Destination	huck-map-1 1.9.116.108
- Ping Test Results:**

Controller IP Address	172.19.28.44
Destination	huck-map-1 1.9.116.108
Send Count	10
Received Count	10
Maximum Time Interval	1 mSec
- Running Link Test:**

Controller IP Address	172.19.28.45
Source	mesh-45-map1 00:0b:85:71:1b:50
Destination	mesh-45-rap1 00:0b:85:5f:fa:f0
- Link Test Results:**

Controller IP Address	172.19.28.45
Source	mesh-45-map1 00:0b:85:71:1b:50
Destination	mesh-45-rap1 00:0b:85:5f:fa:f0
Packet Error Rate	0%
Packets Sent	2488
Packets Received	2512
Good Packets Received	2488
Duplicate Packets Received	0
Big Packets Received	0
CRC Short Packets Received	0
PHY ERR Packets Received	0
CRC ERR Packets Received	24
Average SNR (dB)	19
Highest SNR (dB)	22
Lowest SNR (dB)	18
Average Noise Ratio (dB)	-88
Highest Noise Ratio (dB)	-88
Lowest Noise Ratio (dB)	-89
Average RSSI (dBm)	-68
Highest RSSI (dBm)	-67
Lowest RSSI (dBm)	-70

- Mesh Info on mouse roll over
- Neighbor AP Info
- Ping Test from Controller to AP
- Link Test from AP to AP

# Agenda

- Úvod do metropolitní a outdoor WiFi
- Technologie a architektury pro metropolitní sítě WiFi
  - Komponenty WiFi Mesh
  - Vlastnosti WiFi Mesh
  - End-to-end architektura metropolitních WiFi sítí
  - Zajímavé produkty
- **Aplikace**
  - Využití jedné fyzické infrastruktury pro oddělené logické sítě
  - Fyzická bezpečnost, kamerové systémy
  - Mobilita, dopravní prostředky
  - Služby lokalizace, informace pro turisty
  - Digital Media Signage



# Cisco ServiceMesh Applications



## Municipal

- Public safety (video&voice)
- Land management
- RFID tracking applications
- Surveillance
- Meter reading (utility/parking)
- Traffic management



## Residential

- Data connectivity
- Choice of payment method
- Turbo-button
- Family member additions
- Parental Control
- Location-based applications



## Businesses

- Data connectivity
- Guest access
- Hospitality offerings



## Tourism

- Convention directions
- City events and sightseeing
- Emergency help

# Multifunctional: Several logical networks across single metro wireless infrastructure

Oddělené logické sítě  
Kamerové systémy  
Mobilita, dopravní prostředky  
Lokalizace, informace pro turisty  
Digital Media Signage

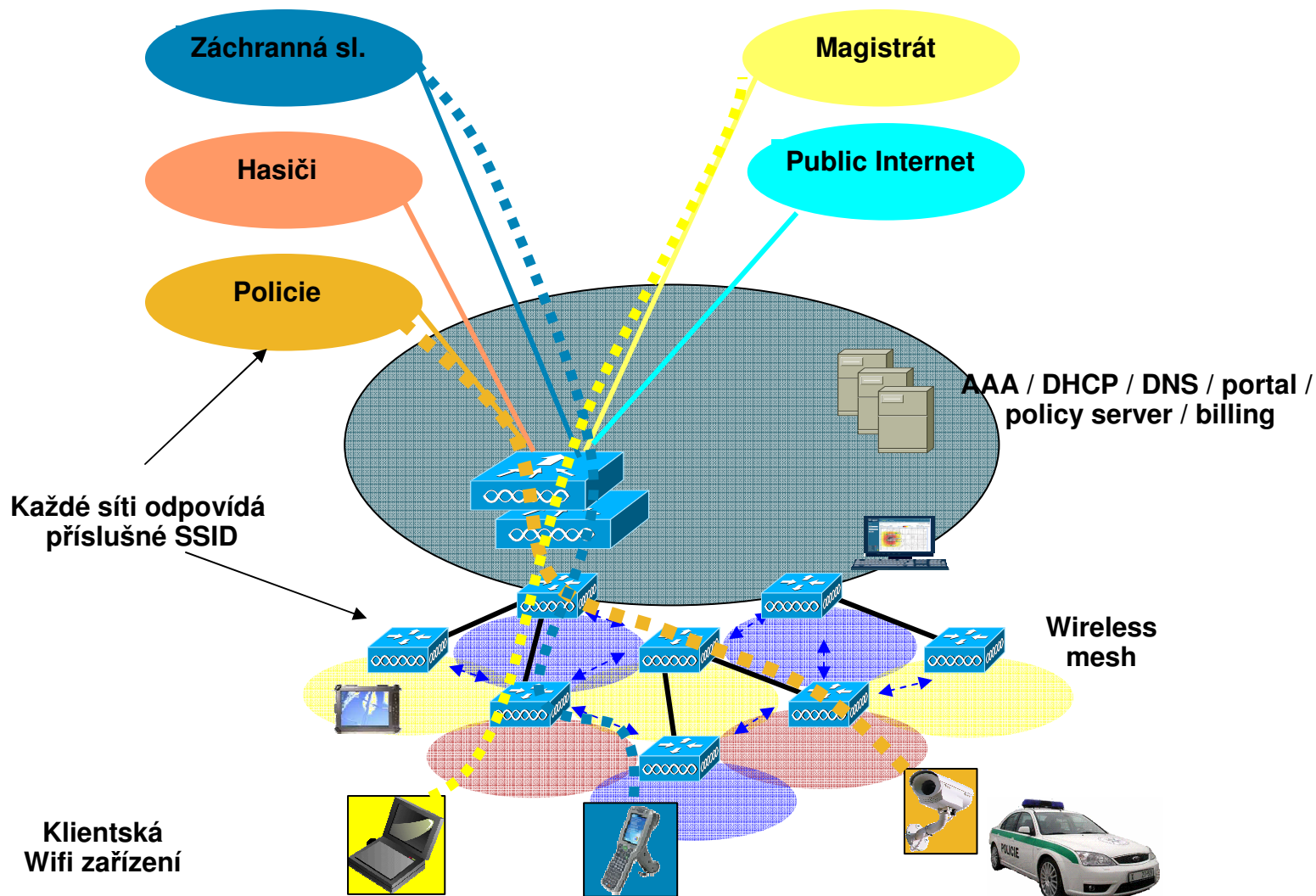

# VideoSurveillance over MetroWiFi

Oddělené logické sítě  
**Kamerové systémy**  
 Mobilita, dopravní prostředky  
 Lokalizace, informace pro turisty  
 Digital Media Signage

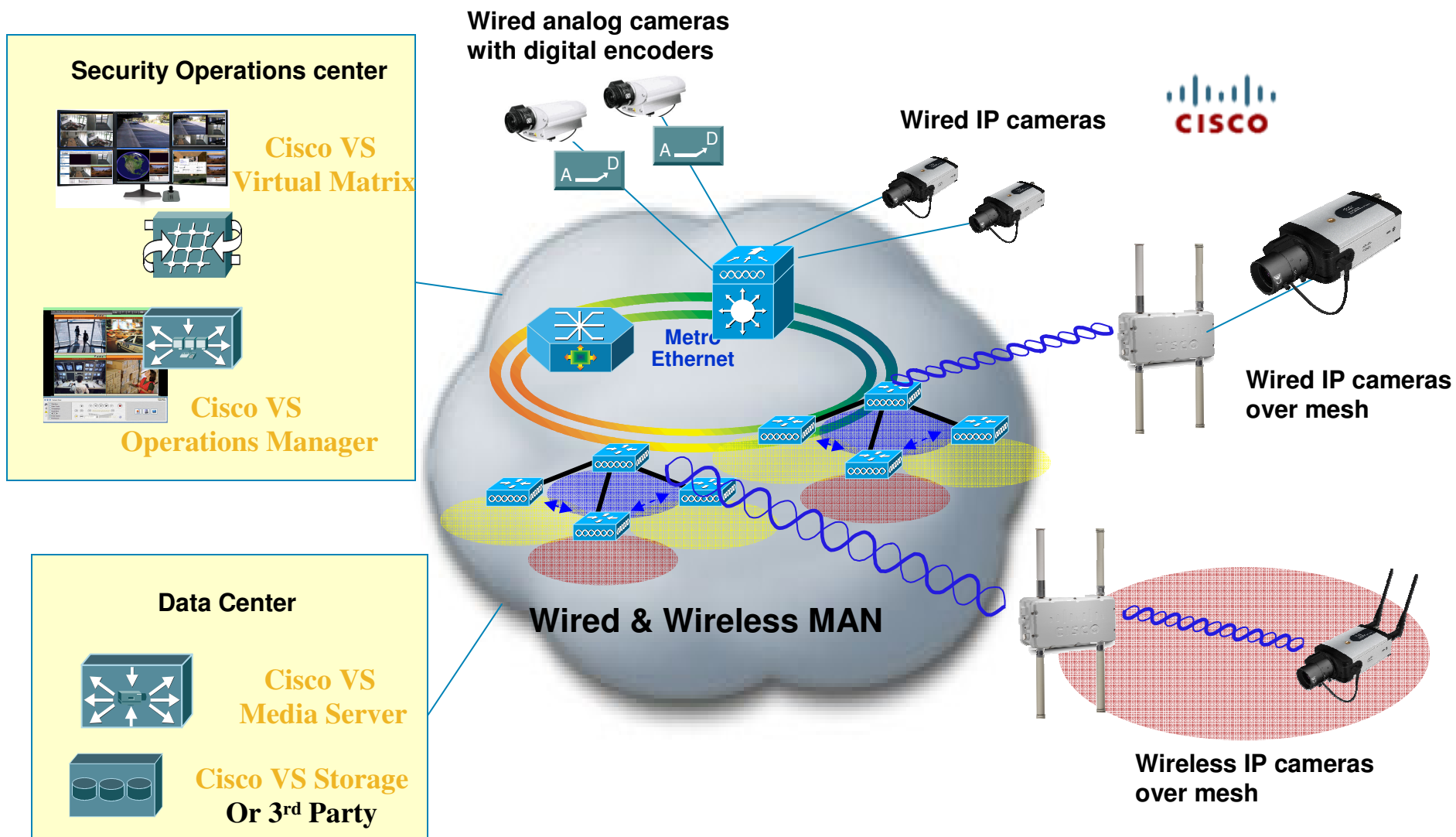



## Video over wireless mesh specifics

- Wireless is shared media
  - Videostream bandwidth depends on resolution and FPS
    - MPEG4, CIF (352x240), 12fps => ~0.5 Mbps
    - MPEG4, 4CIF (704 x 480), 24fps => ~3-4 Mbps
- Assuming Mesh Depth 2 hops max.
- Assuming RAP:MAP ratio max cca 1:5 (depends on image quality)
- Wifi Mesh supports QoS, but cameras have to support QoS marking !!!
  - Some vendors lack DSCP marking mechanisms
  - Cisco IP cameras support QoS 😊

# New Cisco ISR videosurveillance modules used with wireless mesh

Oddělené logické sítě  
**Kamerové systémy**  
Mobilita, dopravní prostředky  
Lokalizace, informace pro turisty  
Digital Media Signage

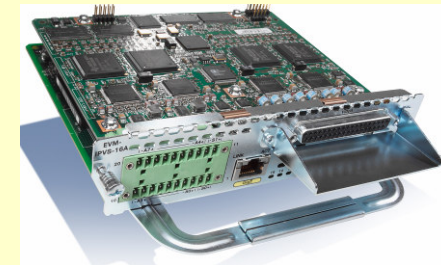
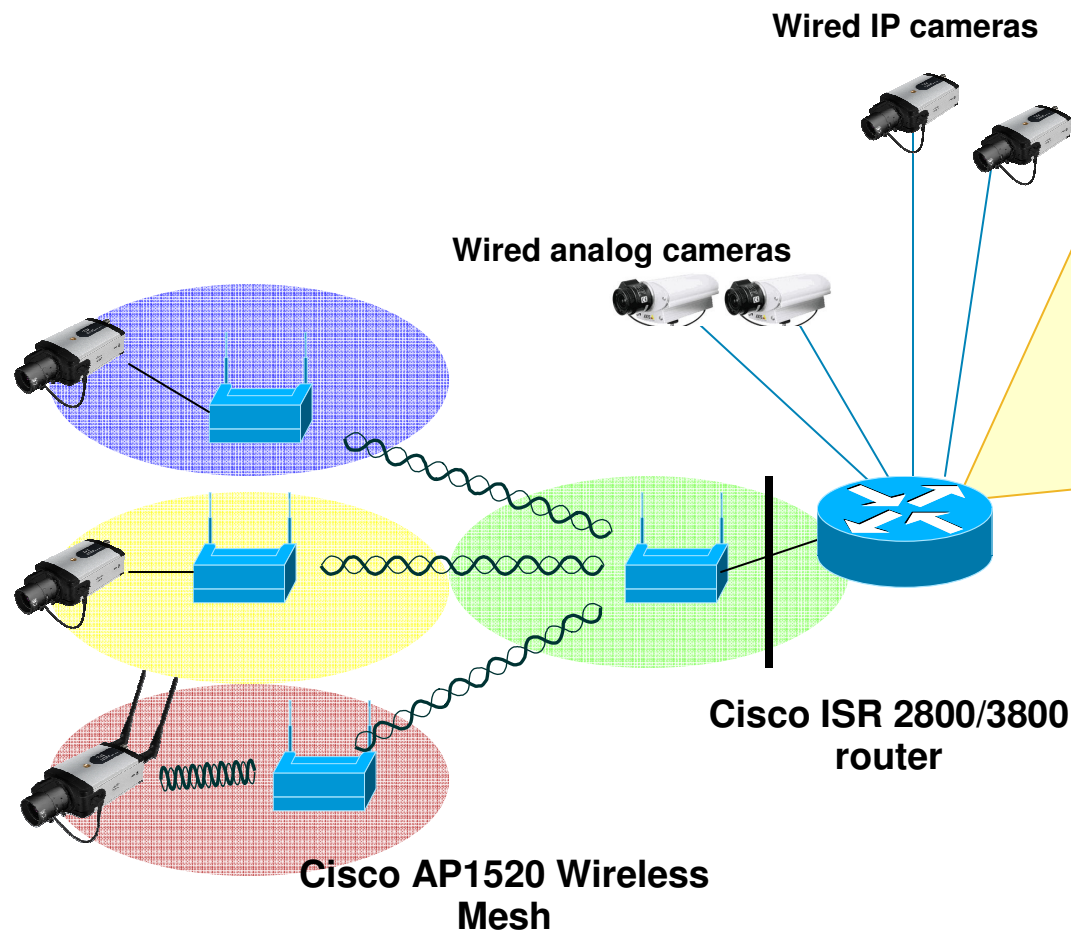

**EVM-IPVS-16A:  
Analog Video  
Encoding Module**

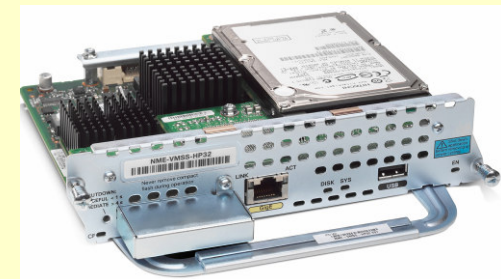

**NME-VMSS: Video  
Management and  
Storage System**



# Cisco IP Video Surveillance Cameras 2500 Series

Oddělené logické sítě  
**Kamerové systémy**  
Mobilita, dopravní prostředky  
Lokalizace, informace pro turisty  
Digital Media Signage

- Cisco Standard Definition IP Cameras
  - Wired Power over Ethernet (POE)
  - Wireless 802.11b, g, n
- High Quality, Excellent Video Images – On Par with Analog Cameras (NTSC, PAL)
- Fully Featured - Day/Night, Audio, Contacts, Alarms
- Networking Features, QoS, Multicast
- More IP Cameras are on the Roadmap incl. HD, outdoor, PTZ

- CIVS-IPC-2500
- Orderable: March 2008



- CIVS-IPC-2500W
- Orderable: June 2008
- FCS: June 2008



# Testy VS přes Mesh – RAP-MAP 880m

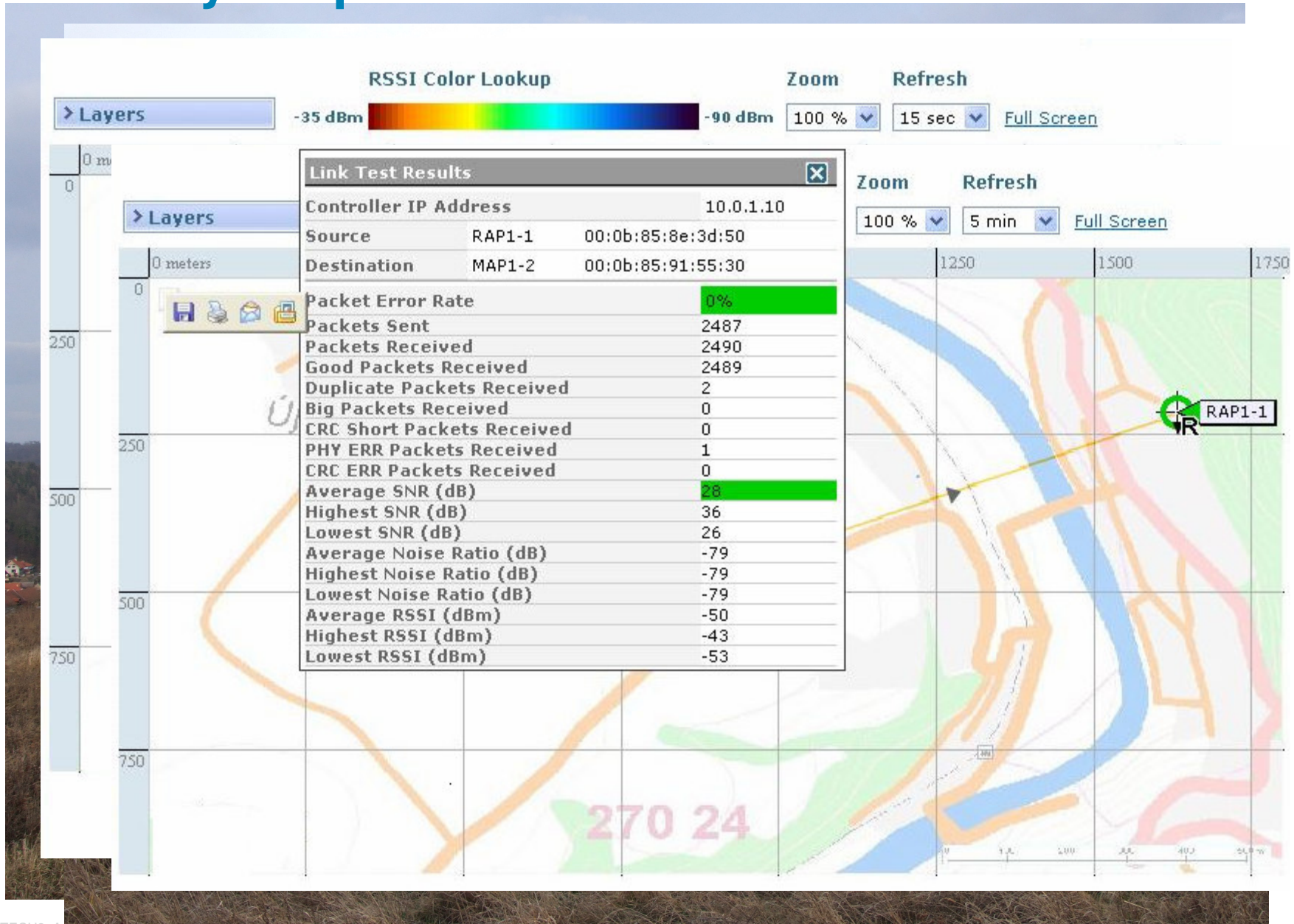

# Testy VS přes Mesh – RAP-MAP 1300m

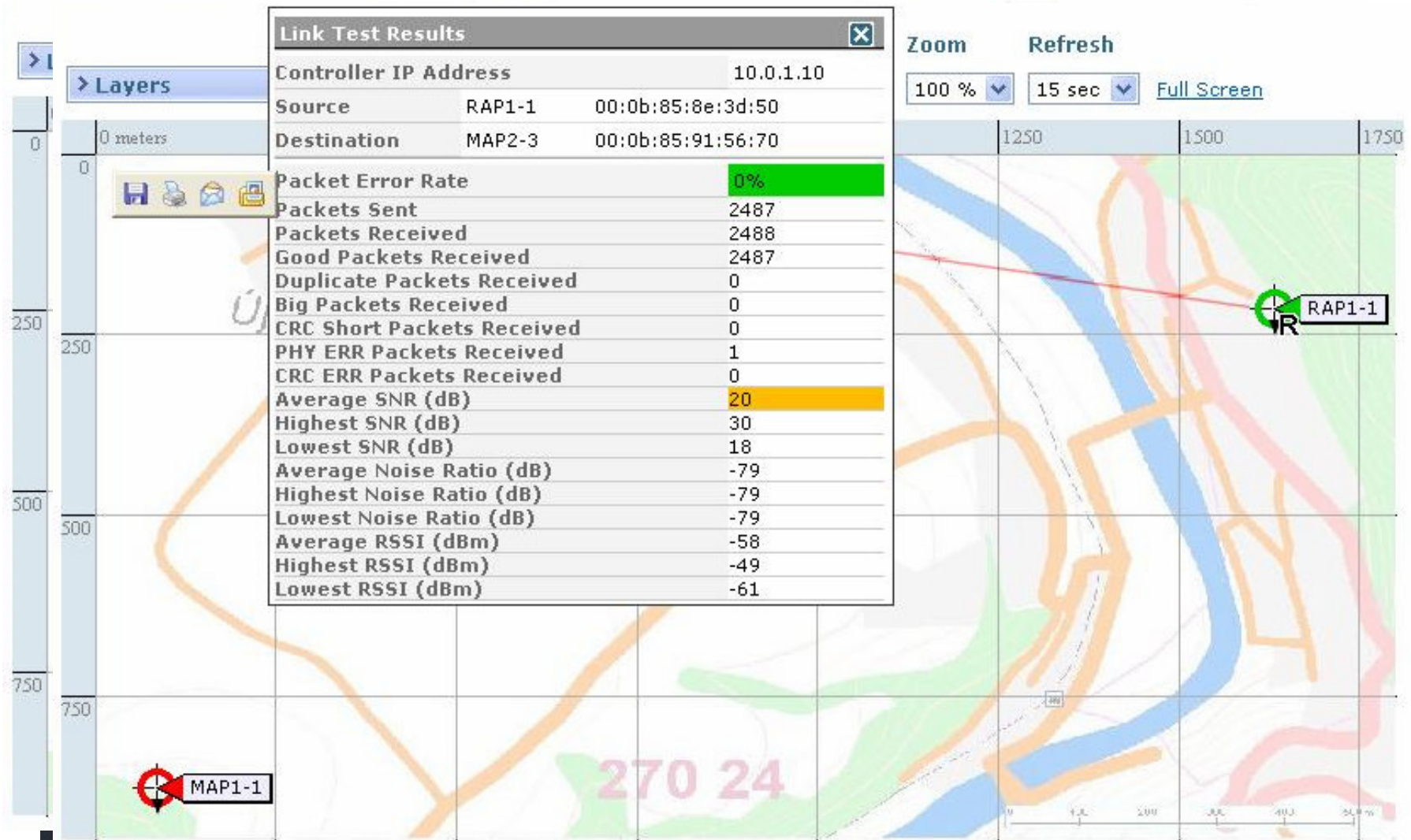

# Metro WiFi as a mobility platform

Oddělené logické sítě  
Kamerové systémy  
Mobilita, dopravní prostředky  
Lokalizace, informace pro turisty  
Digital Media Signage



Technologicky  
vybavený  
policejní vůz

GSM-GPRS

802.11 wifi  
mesh

Mobilní  
směrovač

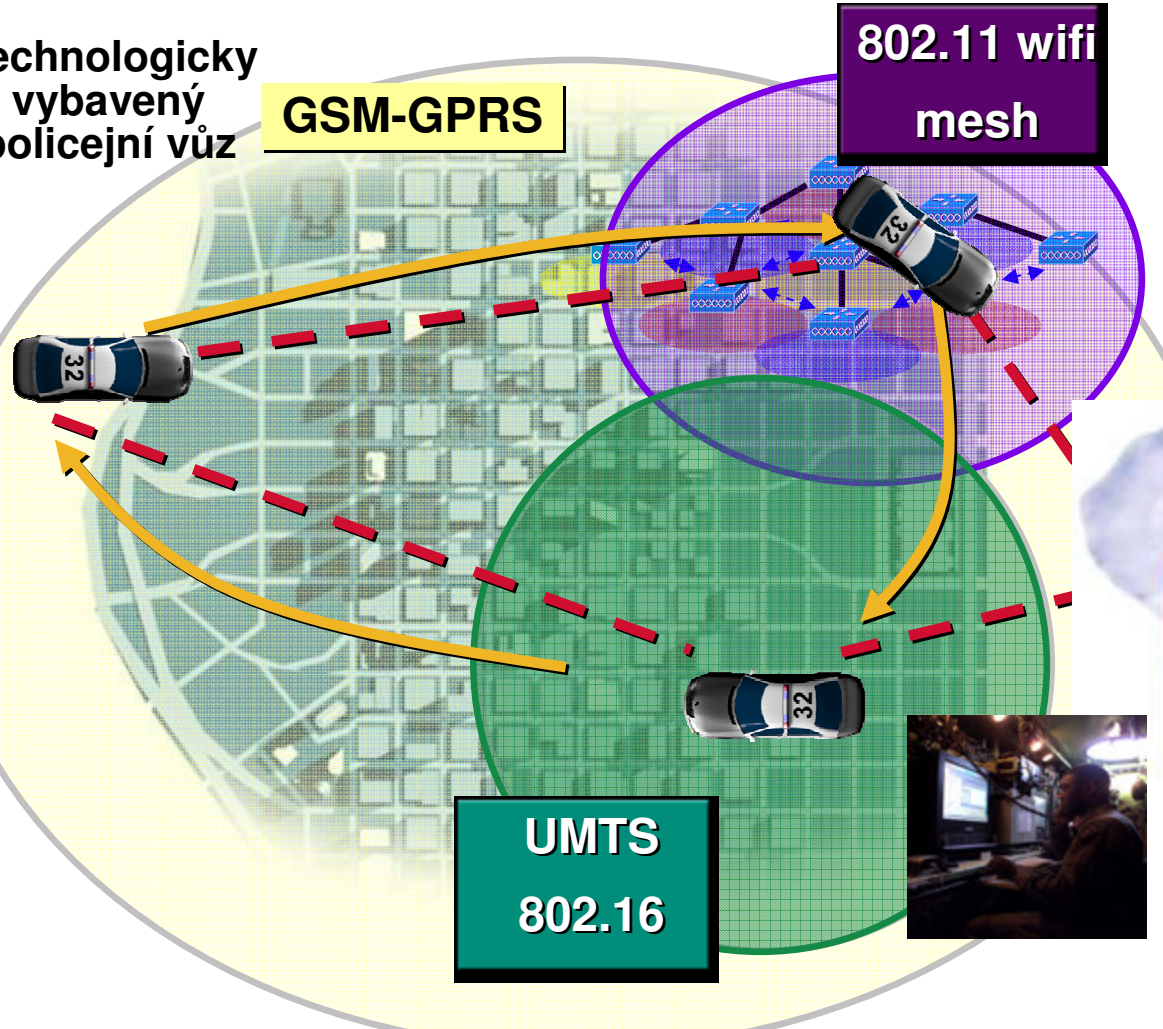

Policejní  
centrála



**Nepřerušovaný přístup = Pokrytí + Rychlost komunikace**

# Public Safety Vehicle Applications

Oddělené logické sítě  
Kamerové systémy  
Mobilita, dopravní prostředky  
Lokalizace, informace pro turisty  
Digital Media Signage

Using **Mobile IP** technology and **MAR3200** mobile router in Metro Wifi

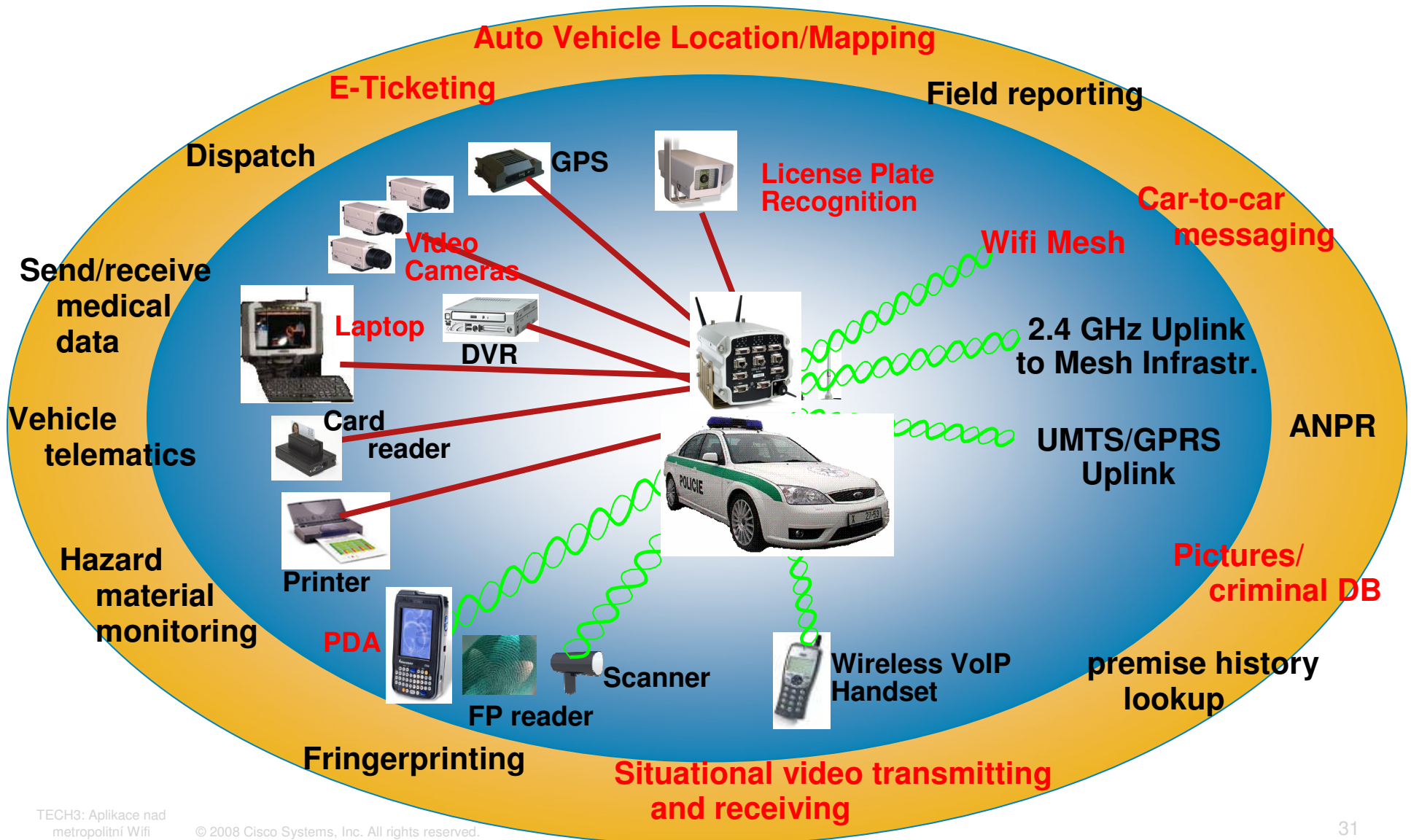

# MAR3200 – Modular Standards-based PC104+ Hardware Platform

Oddělené logické sítě  
Kamerové systémy  
Mobilita, dopravní prostředky  
Lokalizace, informace pro turisty  
Digital Media Signage

## Cisco PC104+ Cards:

- MARC-3250 (IOS Router)
- MARC-3270 (IOS Router)
- FESMIC (4-Port Switch)
- SMIC (4-Port Serial)
- WMIC 4.9 GHz (US)
- WMIC 2.4 GHz
- WMIC 5 GHz

## 3<sup>rd</sup> Party PC104+ Cards:

- Video Server (2/4 Port)
- EVDO / GPS Modem
- UMTS Modem
- Linux Application Blade
- 30-40GB Automotive HDD
- Windows PC Blade
- 4 Port Ethernet Hub
- DSL Modem
- Satellite Blade



**PC104+  
Stack with  
Thermal Plates  
(no moving parts)**



**Rugetized enclosure**

- Cisco IOS Software router platform that helps create the Metro Mobile Network
- Flexible, high performance & rugged design for mobile & fixed environments
- Integrated 802.11 a/b/g
- Secure, scalable, and managed data, voice and video communications
- Seamless mobility across wireless networks independent of location or movement
- Advanced IP services and interoperability through Cisco IOS Software



# Why Choose a Mobile Network vs. a Mobile PC?

Oddělené logické sítě  
Kamerové systémy  
Mobilita, dopravní prostředky  
Lokalizace, informace pro turisty  
Digital Media Signage

## Car with PC Based Access



- Single networked device (PC)
- Multiple devices may require individual radios & subscriptions
- Windows OS for both access and applications
- Mobility client SW installation required for each device
- Limited 802.11 range for client to AP
- Lack of integrated security (separate SW installed and maintained)
- PC crash from virus, security patch, or application conflict, etc. will cause all devices & applications to lose network connectivity
- Limits on number of wireless technologies supported at once and in the future

## Car with Cisco Mobile Networking Solution



- Multiple wired & wireless devices
- Integrated radio subscriptions for all apps
- Increased Radio Range with externally mounted high-gain antennas over a simple PC client card
- Investment protection : compatible with future wireless technologies
- 802.11 Access Point for vehicle Hotspot
- Connects to any WAN link including 700-900 MHz, cellular, & future WAN technologies
- Cisco IOS Software OS for network reliability
- Cisco integrated network security (Firewall, Encryption, AAA, IDS)
- QoS & Multicast for voice and video
- Flexible, rugged hardware designs meeting MILSPEC and SAE specs.
- Standards based mobility (Mobile IP)
- Remote debug and troubleshooting tools through Cisco IOS software

# High-speed Roaming

Oddělené logické sítě  
Kamerové systémy  
Mobilita, dopravní prostředky  
Lokalizace, informace pro turisty  
Digital Media Signage

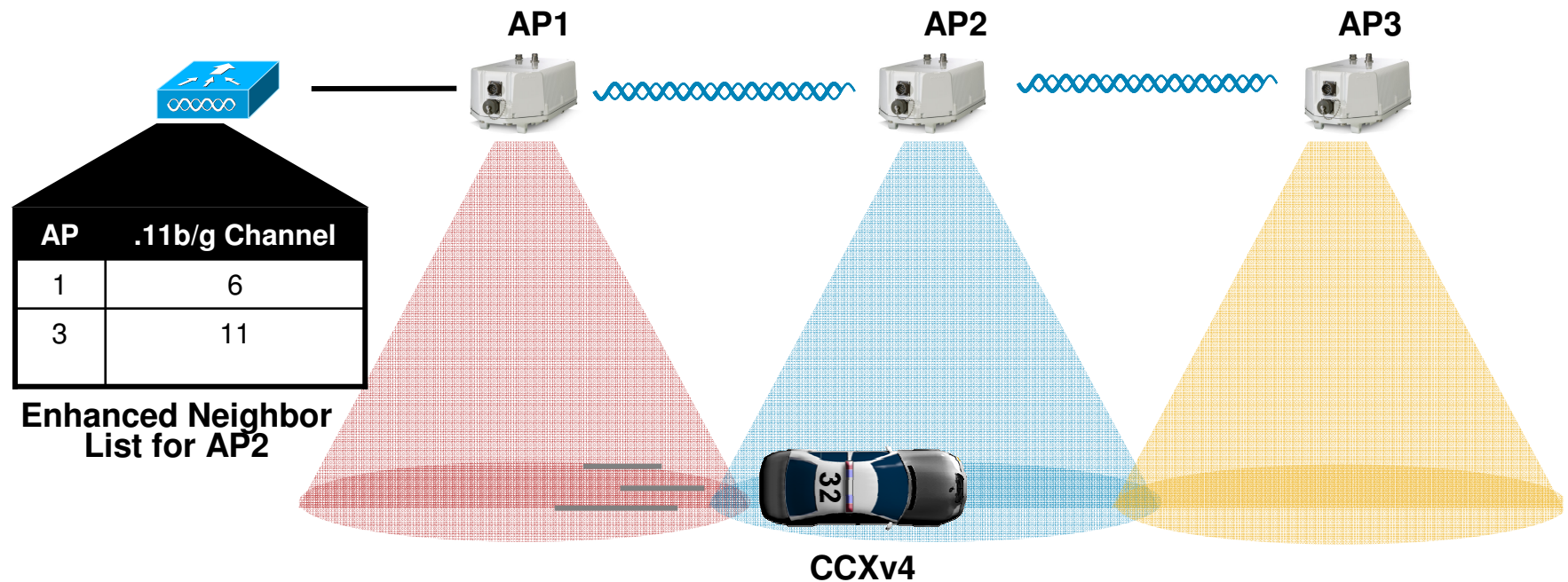

Client can roam at up to 70 MPH / 112 Km/h

CCXv4 clients only

Updated with AP neighbor information

Roam time <50 ms

# Intelligent Vehicle Network Roaming with Multiple Client Profiles

Oddělené logické sítě  
Kamerové systémy  
Mobilita, dopravní prostředky  
Lokalizace, informace pro turisty  
Digital Media Signage

## Priority 2: Citywide Mesh Network

## Priority 1: Command Vehicle Mesh Access Point

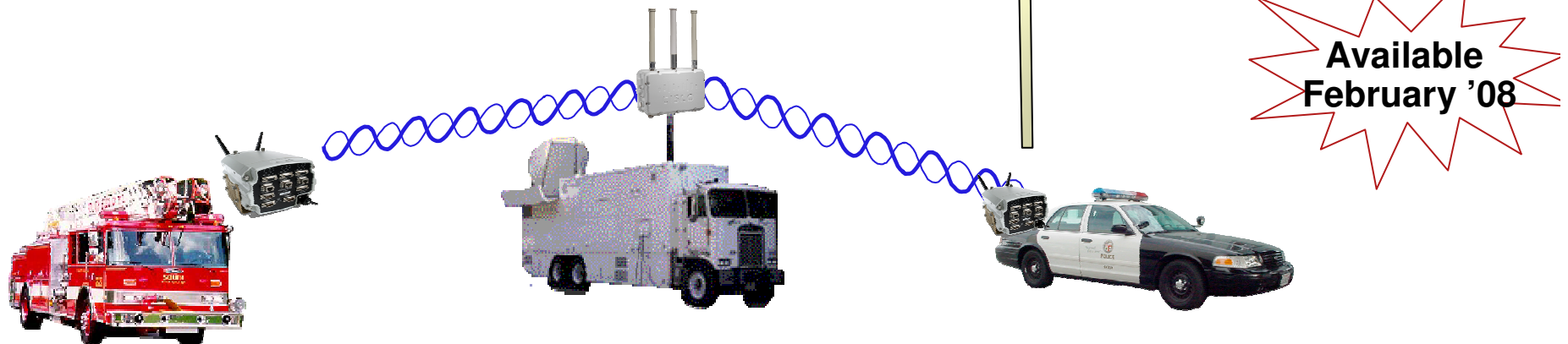

**In this example, prioritized client profile feature on the Cisco 3200 enables the mobile network to prioritize command vehicle AP over citywide mesh**

# Case Study

## Zurich Police, Mobile IP over 3G & WiFi

Oddělené logické sítě  
Kamerové systémy  
Mobilita, dopravní prostředky  
Lokalizace, informace pro turisty  
Digital Media Signage

- Mobile communication system is a mobile IP network in the patrol vehicle, terminal and peripheral devices are linked via Ethernet.
- In addition to in-car PCs or laptops, other possible devices may include IP video cameras, scanners, printers or VoIP phones.
- Access technologies
  - WiFi (City Police bases)
  - UMTS/HSDPA (mobile operator)
  - Edge/GPRS (mobile operator)
- The device will always select the connection that allows the greatest bandwidth.
  - Mobile IP technology
- Plan for 50+ vehicles



# Case Study

## Oxford Buses – MobileIP over 3G & WiFi

Oddělené logické sítě  
Kamerové systémy  
Mobilita, dopravní prostředky  
Lokalizace, informace pro turisty  
Digital Media Signage



- GoAhead Group operate a busy commuter service between London and Oxford
- Company wanted to add value to their service and allow for additional applications such as CCTV and online ticket purchase
- Additionally pressure from competitive service..
- Deploying MAR3200 with 2 x 3G HSDPA/UMTS data cards per vehicle and allowing connections to bundle for higher throughput.
- Plan to extend 25 buses and deploy to 65 vehicles.



# Location-Based Services

## Web Portal Advertising Insertion

Oddělené logické sítě  
 Kamerové systémy  
 Mobilita, dopravní prostředky  
 Lokalizace, informace pro turisty  
 Digital Media Signage

The screenshot shows the mComm website interface for Denver, CO. The page features a navigation bar with the ESPN ZONE logo and the slogan "CATCH ALL YOUR SPORTS ACTION HERE". The main content area includes a "Welcome To Denver" section with a cityscape image, a login form, a map of Denver, and several advertisements. Callouts in yellow boxes point to specific elements: "Local Banner" points to the ESPN ZONE header; "Local Search" points to the search bar; "Local Content" points to the login form; "Local Roaming" points to the "Roaming Login" section; and "Local Ads" points to the Hyatt Regency Denver advertisement.

# Digital Media Signage over MetroWiFi

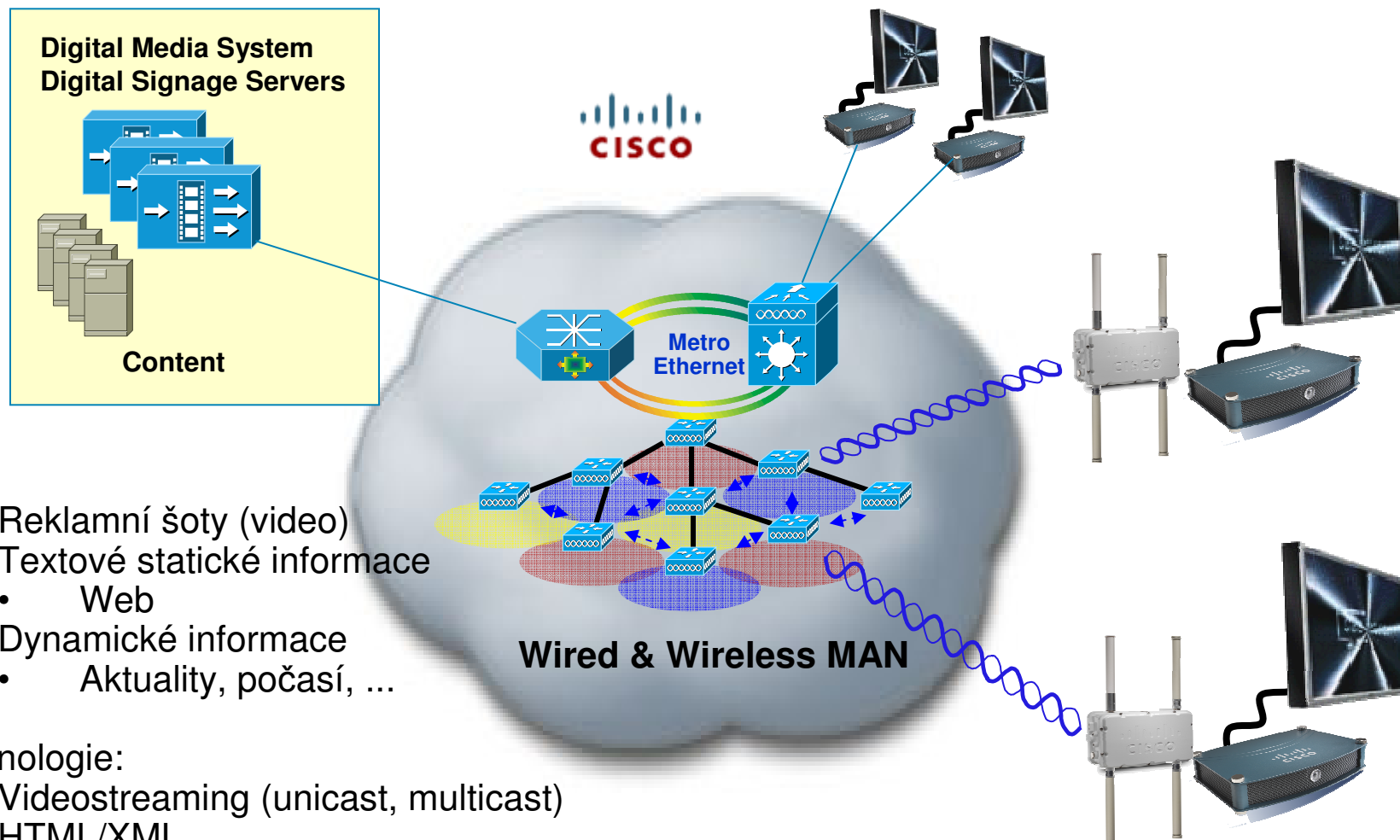

1. Reklamní šoty (video)
2. Textové statické informace
  - Web
3. Dynamické informace
  - Aktuality, počasí, ...

## Technologie:

- Videostreaming (unicast, multicast)
- HTML/XML
- Dávkový přenos FTP

# Dotazy?



Pavel Křížanovský: Aplikace nad metropolitní WiFi infrastrukturou (TECH3)